



# GOAL POST SAFETY

ANCHOR     CHECK     RESPECT

For more information contact Football Queensland 07 3208 2677 or [info@footballqueensland.com.au](mailto:info@footballqueensland.com.au)

## Background

In the sport of football, the safety of everyone involved and playing both indoors and outdoors, remains paramount. There have been at least 49 deaths and a range of serious injuries worldwide related to moveable soccer goals. In Australia there have been at least seven deaths and one incident resulting in the person becoming paraplegic. Unfortunately, the victims are often young kids and teenagers. In conjunction with the Australian Standard 4866.1-2007 Playing Field Equipment – Soccer Goals and the QLD Office of Fair Trading Safety Standards for Moveable Soccer Goals 2008, we remind all Clubs of the requirements to abide by regarding the use and storage of goalposts. Moveable soccer goals are defined as a freestanding structure consisting of at least two upright posts, two side ground bars, a rear ground bar, a crossbar and support bars (for a more detailed definition please refer to Definitions at the end of this article).

## Hazards

Death and serious injury can happen if moveable soccer goals are installed incorrectly or when they are used inappropriately. Specifically, blunt force injuries and trauma to the head, neck, chest and limbs can occur from moveable soccer goals due to:

- Instability
- Goals becoming unanchored
- Goals with inadequate anchoring
- Inappropriate or ineffective installation
- Inappropriate use, such as swinging on goalposts or cross bars

## Anchoring Goals

All moveable soccer goals weighing 28kg or more are required to be anchored securely to the ground. It takes 200 kilograms to properly anchor a full size portable soccer goalpost which equals 10 (300mm) stakes and 12 bags of sand, or 10 bags of cement mix.

Moveable goals shall have two side ground bars and a rear ground bar. Goals shall be provided with an effective ground anchor system and instructions on the use of the system. At least one anchor point shall be provided at each side of the rear ground bar.

## Safe Portable Goal Storage

Moveable goals should be stored face-to-face and secured to one another as shown in the image. To minimise the risks of potential dangers and harm, goals should be stored as shown after all games and especially when not in use during the off-season. Securing the goals face to face can be done either at both ends of the goals or once at the top cross bar. Securing the goals as described, restricts the ability of the goals tipping over.



## Warning Labels

When purchasing portable goals it is a requirement that portable goalposts comply with Australian Standard AS4866.1-2007 and display the regulated Warning notice. Do not purchase portable goals that weigh 28kg+ and have not been tested and meet AS compliance.

All moveable soccer goals weighing 28kg are required to be affixed with a Yellow Warning Sticker alerting of the dangers of playing and climbing on goals and goals tipping over. The warning label must be marked clearly and legibly with upper case letters at least 25mm high and lower case letters at least 12.5mm high. The warning labels must be placed in three positions on the goal: the underside of the crossbar and the outside of both goal upright posts. The warning label must read:

**“WARNING - ALWAYS ANCHOR GOAL - NEVER CLIMB OR HANG ON CROSS BAR.**

Unanchored goals can tip over causing serious injury or death.”

## Anchor, Check Respect Campaign

Football Queensland endorses the Anchor, Check, Respect: The game plan for moveable soccer goal safety campaign. It is a national safety initiative by Football Federation Australia and Product Safety Australia, designed to help prevent deaths and serious injuries and make soccer a safe activity for everyone involved.

Football Queensland encourages that you access the following resources relevant to the Anchor, Check, Respect campaign:

**VIDEO:** [Anchor, Check, Respect: The game plan for moveable soccer goal safety](#)

**BOOKLET:** [Safe soccer goals guide: Keeping kids safe before, during and after the game](#)

**POSTER:** [The game plan for moveable soccer goal safety - Anchor, check, respect poster](#)



Unsafe moveable  
soccer goals  
can kill.

## Definitions

### Movable Goal

A freestanding structure consisting of at least two upright posts, two side ground bars, a rear ground bar, a crossbar and support bars as shown in the image.

A movable goal is designed—

- a) to be used by adults or children for the purposes of a soccer goal;
- b) to be used without any other form of support or restraint (other than pegs, stakes or other forms of temporary anchoring device); and
- c) to be able to be moved to different locations.

NOTE: A soccer goal that is supported by a sleeve set in the ground is a semi-permanent goal, not a moveable soccer goal.

### Permanent Goal

Any goal fixed by concrete or other material to ground, with or without net supports.

### Semi-Permanent Goal

Any goal designed to be inserted into a ground sleeve and thereby able to be taken from the field during the off-season.

### Determination of Stability

For movable goals the test procedure shall be as follows:

- (a) Install the goal in accordance with manufacturer's instructions on a horizontal surface using the recommended minimum ground anchors
- (b) Apply a horizontal pull force of 1100 N to the centre of the crossbar for no less than 60 seconds and no more than 70 seconds in a direction that is horizontal, perpendicular to the crossbar heading outwards from the goal opening.
- (c) Determine if the unit falls over or fails to return to its original position.

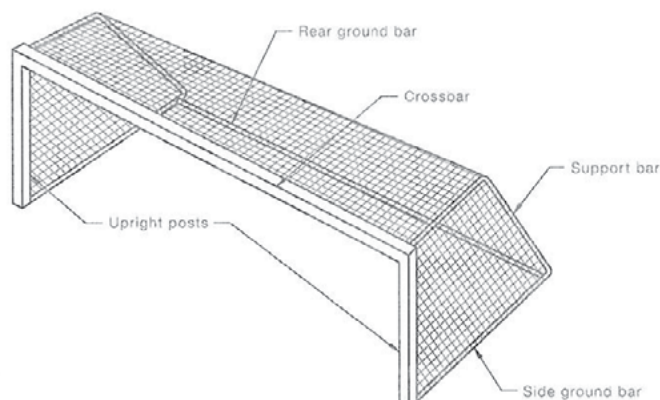

# THE GAME PLAN:

## MOVEABLE SOCCER GOAL SAFETY

Unsafe soccer goals can kill. There are simple ways to help prevent death and serious injury from happening during and around the game.

## ANCHOR.

Anchor moveable soccer goalposts securely into the ground.

It takes 200 kilograms, which equals:

- 10 stakes
- 12 bags of sand, or
- 10 bags of cement mix.

## CHECK.

Before every game or training session, test that the moveable soccer goals are properly secured and safe to use.

1. Ensure there are no children around the goalpost.
2. Shake the goalpost using both hands and push it from behind.
3. If the goalpost falls, don't use it until it has been properly secured.

**Don't use it if it's not safe.**

## RESPECT.

Ensure that no one climbs, swings or plays on a moveable goalpost.

Store the moveable goalposts safely when not in use.



Melbourne Victory Captain and safe goalposts ambassador Adrian Leijer



[www.productsafety.gov.au/soccergoals](http://www.productsafety.gov.au/soccergoals)